



**MIX S.r.l.**

CERTIFICATE SYSTEMS UNI EN ISO 9001

**MIXING SYSTEMS AND  
COMPONENTS FOR PLANTS**

## MIXER MIX® TYPE MXC



1

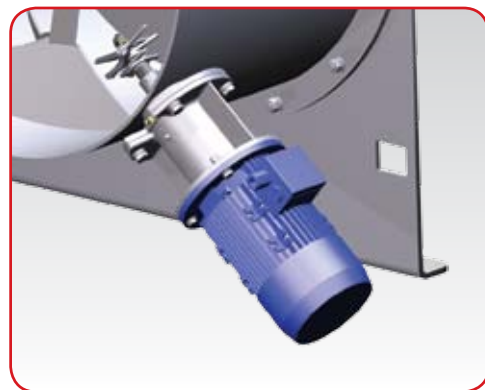

### HOMOGENIZER COMPLETE WITH KNIVES

- Efficient Lump-breaking action
- Improved mixing

### MIXER

- Optimal mixing
- Minimum residue after discharge
- Accurate finishing

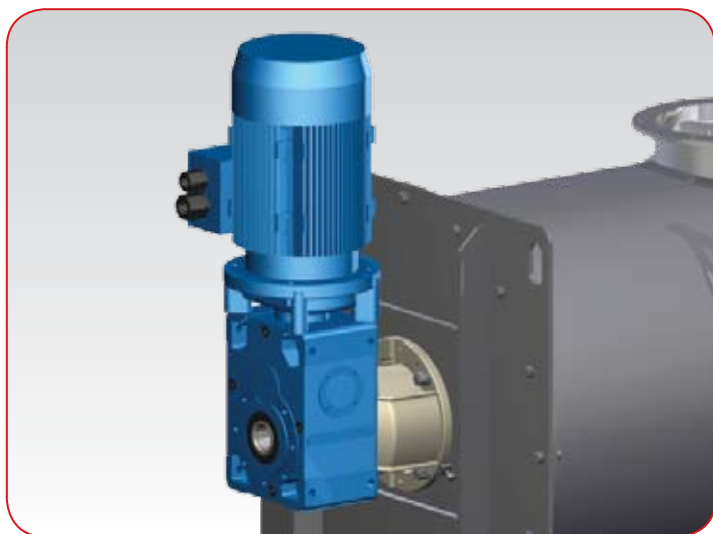

### COMPACT DRIVE

- Optimized performance
- Low maintenance
- Reduced encumbrance

2

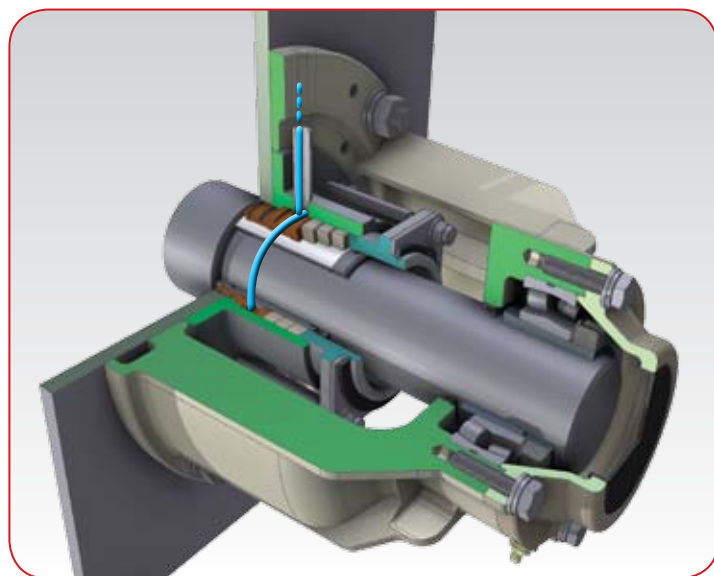

### SECTION OF SHAFT AND SEAL

- Perfect sealing
- Predisposition for fluid blowing
- Easy maintenance

3

## ROUND DISCHARGE DOOR WITH CYLINDER

- Self-cleaning system with lip seal
- Perfect reconstruction of the circularity of the mixing chamber

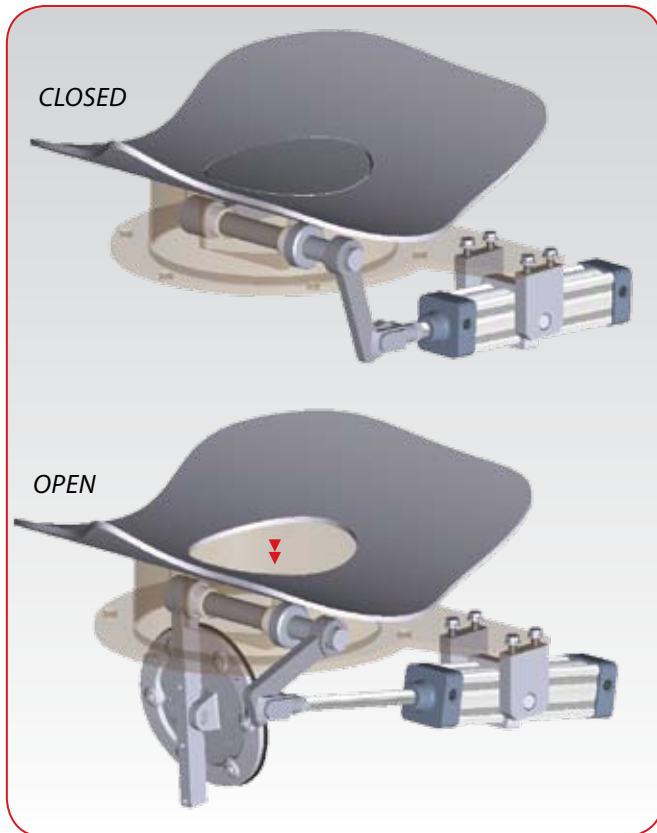

## INSPECTION HATCH

- Excellent sealing -
- Total safety -
- Easy inspections -

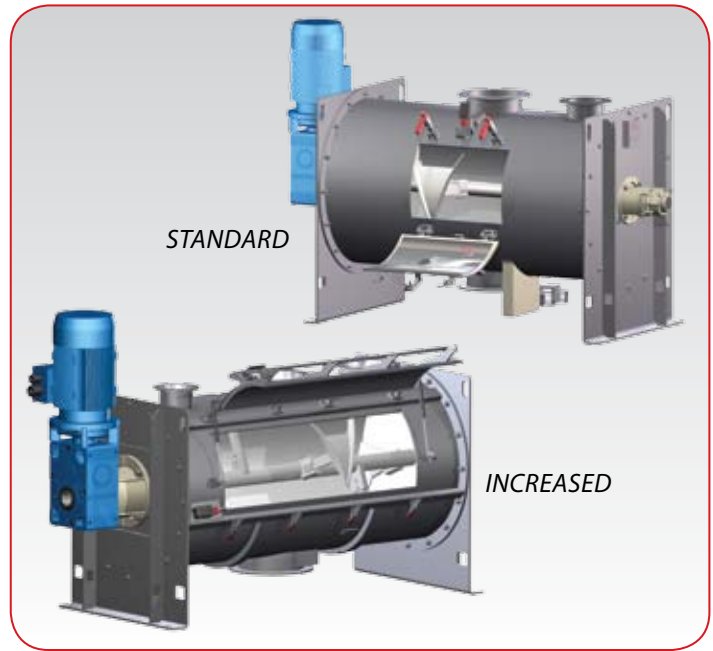

## BOMB DISCHARGE DOOR WITH CYLINDER

- Reduced discharging time -
- Minimum residue after discharge -
- Maximum productivity -

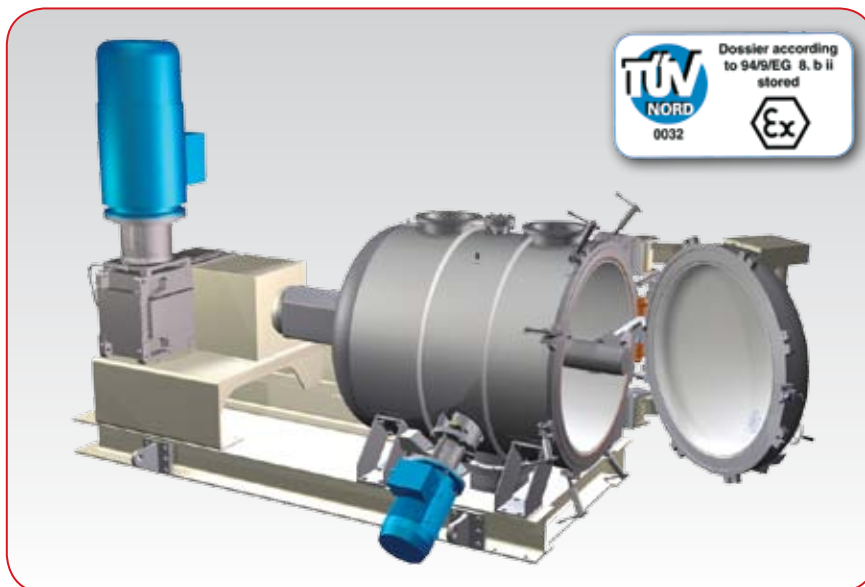

## ATEX AND PED CERTIFICATION

- Wide range of products certified ATEX and PED
- As an example is shown a vacuum dryer with:
- Heat exchanger built directly on the mixing chamber
- Openable side for easy cleaning and maintenance

