

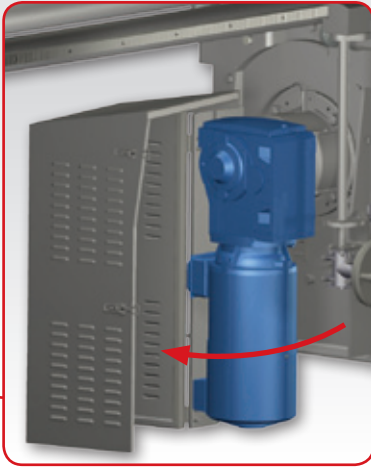

MIXER MIX® TYPE MXC

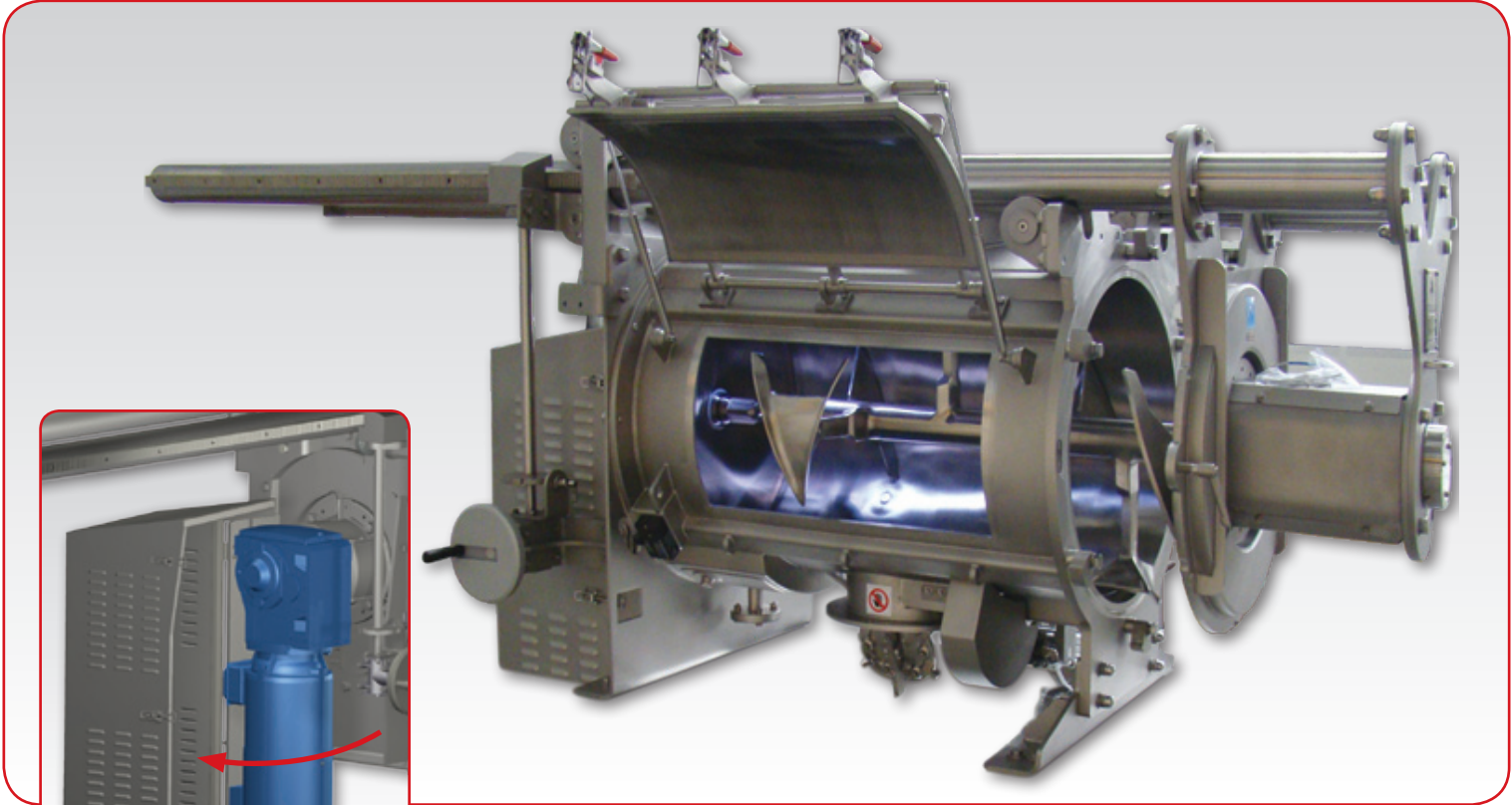

COMPACT DRIVE

- Optimized performance
- Low maintenance
- Reduced encumbrance
- Protection carter easy access

MIXER WITH ROTOR ASSEMBLY EXTRACTABLE

- Extractable rotor-shaft, for an easy and efficient cleaning/sanitization process
- The rotor-shaft can be cleansed out of the mixing chamber
 - Extraction of the rotor-shaft is controlled by hands, above self-supporting runners
- Mixing-chamber with heat-exchanger and thermal insulation
 - Closing system with safety blocks
 - Accurate finishing

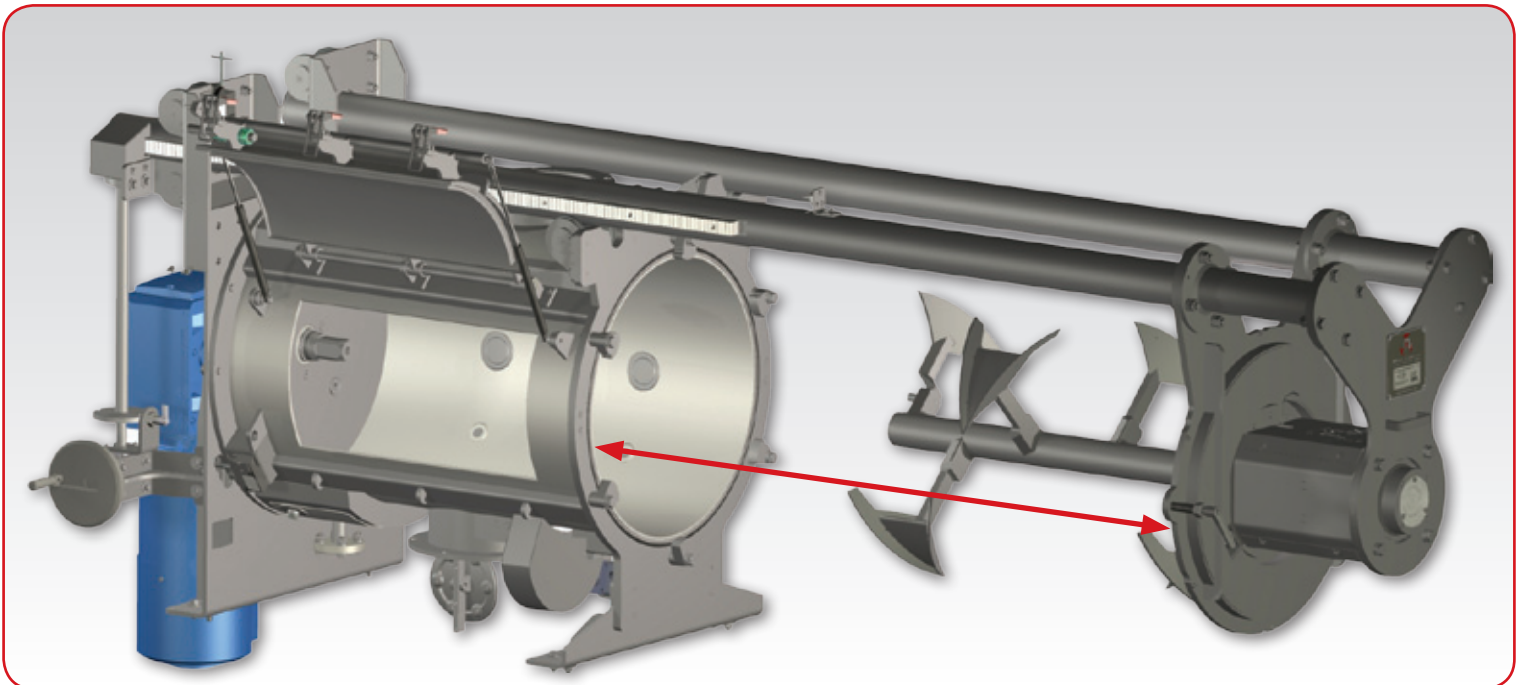

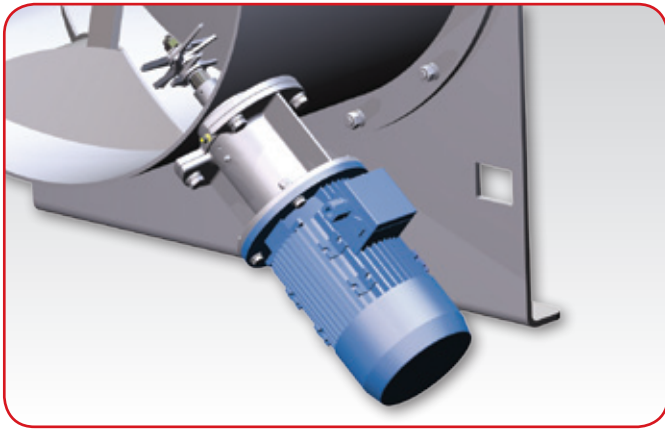

HOMOGENIZER COMPLETE WITH KNIVES (OPTIONAL)

- Efficient Lump-breaking action
- Improved mixing
- Wide range of knives, for specific uses

3

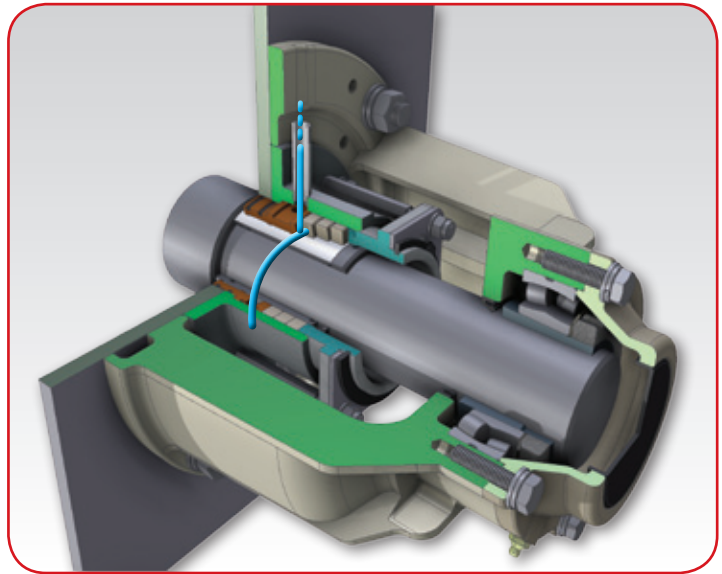

SECTION OF SHAFT AND SEAL

- Perfect sealing
- Predisposition for fluid blowing
- Easy maintenance

4

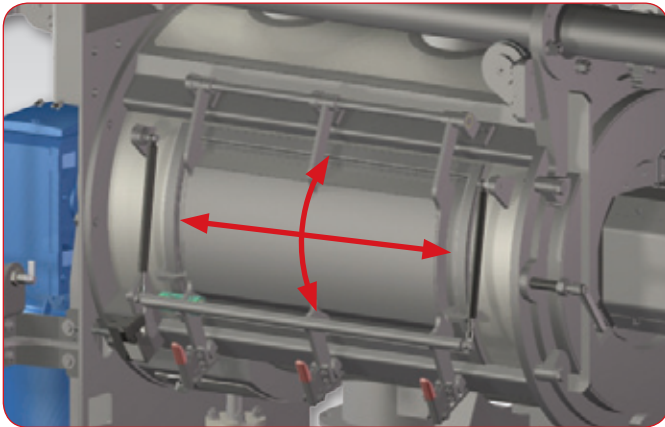

INSPECTION HATCH

- Excellent sealing
- Minimal amount of space, when the hatch is open
- Inspection-hatch with gas-struts
- Total safety
- Easy inspection

5

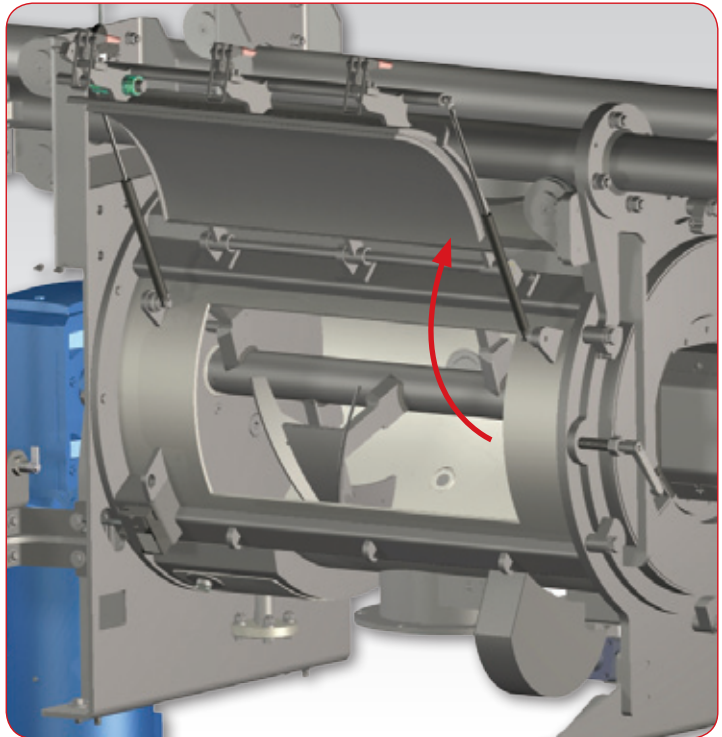

ROUND DISCHARGE DOOR WITH CYLINDER

- Self-cleaning system with lip seal
- Perfect reconstruction of the circularity of the mixing chamber
- Minimum residue after discharge

6

